

Analysis of High Impedance Fault in IEEE 9 bus System by Signal Processing Tools using MATLAB/Simulink Model

Sudipta Das, Pratyusha Biswas Deb, Susmita Dhar Mukherjee, Soumya Das, P.S.Majumdar, Am-barnathe Banerji

Abstract— High impedance faults are generally not detected by conventional protection functions because of magnitude of impedance involved in fault path different than the conventional fault current profiles like overcurrent, grounding. By applying Fast Fourier Transform technique with operation, the fault detection instruments give correct fault result with saving the time.

Index Terms— High Impedance Fault - HIF, Fourier Transform - FT, Fast Fourier Analysis -FFT, Power System Measuring Units - PMU, MATLAB/Simulink

1 INTRODUCTION

THIS paper has been discussed about High Impedance Fault in IEEE 9 bus System by Signal Processing Tools using MATLAB/Simulink Model. A 3-phase AC power system operating under normal condition has a standard magnitude of both current and voltage which is equally distributed across each phase, when a fault occurs on the system a high short circuit [1] current flows in system causing unbalanced voltage and reduces the effective impedance of the system which destroys and damages the protective equipment connected in the system. The High Impedance Fault (HIF) current random behavior and its low magnitude cause difficulties for a reliable detection by traditional protection methods. Therefore, the hazards for grid devices and people's safety associated with HIFs motivate better at suitable detection techniques. Short-circuit currents are harmful for two reasons-the first is that even a short-time flow of heavy current will over-heat the equipment, the second is that the flow of short-circuit currents through the current carrying parts produces forces of electrodynamic [2] interaction which may destroy or damage the equipment. This is why all the elements of any electrical installation are designed and selected for a thermal and a dynamic stability is sufficient to withstand the largest possible flow of short circuit current that may occur in the given installation. The severest conditions in service are those of the switching devices during a short circuit. These devices are circuit breakers [3] and the fuses, whose function is to interrupt the fault current within a short period or time (0.05 -0.3 second) and thereby switch out the faulty section. Due to harmonics power system equipment like relay, circuit breaker and oth-

ers are working with malfunction so, they don't work properly so fault current detection and over voltage detection are get failed and a fault occurs in the total system. So, short circuit current analysis and harmonics analysis with quick function is most important task for the protection function. If the fault current analysis is done quick then protective equipment can do their operation within the time.

Therefore, HIF occurrence is a major challenge for distribution networks. Also, the electric arc leads to distinctive features on the fault current waveform as well as a peculiar frequency spectrum. Consequently, several types of research stimulate the use of harmonic content to detect HIF faults. Thus, this paper presents a study of a variant of the FT, called Fast Fourier Transform [4] (FFT)".

In this paper, short circuit current analysis and harmonics analysis is done with the Fast Fourier transform (FFT). So, the fault current FFT analysis is done for protection operation of total electrical system within the time for completing the fault clearing operation within the 'critical fault clearing time' to maintain the steady state stability.

2 SYSTEM MODELLING

This section presents the methodology proposed in this paper concerning implementing an electrical system, the HIFs, and other events related to electrical transmission and distribution systems, which are required to prove the method's robustness. Therefore, the simulations were carried out according to the following subsections.

2.1 High Impedance Faults

High Impedance Faults (HIFs) on distribution feeders are defined as abnormal electrical conditions that cannot be detected and cleared by conventional protection schemes, due to their low fault current. Faults resulting from neighboring objects making prolonged contact with the energized line can endanger human life, potentially causing severe electrical burns, electrocution or fires. Additionally, the arcing associated with HIF may also lead to serious damage to the power system. HIF occur when the energized overhead distribution feeder conductors have undesired physical contact with a quasi-insulating object nearby, such as asphalt road, gravel or tree limbs. The current from this type of fault may be not large enough to be detected by conventional protection devices. Therefore, the downed energized conductor may become a potential hazard to public safety. Furthermore, arcing is often associated with these faults.

HIF typically caused by: broken conductor in touch with ground and other surfaces but still connected to source, Intermittent contact with tree limbs or other objects, contaminated or falling equipment etc.

2.2 Test System

All developed countries depend upon electrical energy for industrial, commercial, agricultural, domestic and social purposes. Therefore, the basic infrastructure, that is, generating stations and transmission and distribution lines have become a crucial part of modern socio-industrial landscape. So, we choose IEEE-9 BUS System for standard calculation and simulation, where 3 generators are connected with 3 Transformer, then power is transmitted over transmission line and it distributed in 3 load buses and 1 bus specified as swing bus. It is a specially designed grid system which has 9 buses arranged in a specific pattern in accordance to IEEE norms. Simulation will be applied on this test system.

- **Sudipta Das** is currently pursuing masters degree program in power system in Narula Institute of Technology, India, PH-6290606754. E-mail: sudipta19x@gmail.com
- **Pratyusha Biswas Deb** is currently Assistant professor in EE Department in Narula Institute of Technology, India, PH-9748941162. E-mail: pratyushabiswas85@gmail.com
- **Susmita Dhar Mukherjee** is currently Assistant professor in EE Department in Regent Education and Research Foundation, India, PH-9432574816. E-mail: susmita.dhar@gmail.com
- **Soumya Das,** is currently Project Engineer, Larsen & Tubro Limited, Jeddah, Saudi Arabia India, PH-+966502737797. E-mail: soumya712das@gmail.com
- **P.S.Majumdar,** is currently former professor in Department of Physics, A.P.C College, India, PH-8017894819.
- **Ambarnathe Banerji Deb** is currently professor in EE Department in Narula Institute of Technology, India, PH-9073322511. E-mail ambarnathbanerji@gmail.com

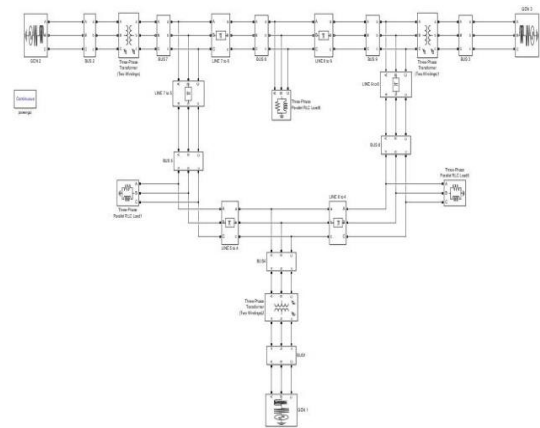

Fig 1: IEEE 9-Bus standard system

2.3 Simulation Software

MATLAB is a programming and numeric computing platform software used to analyze data, develop algorithms, and creates models and design systems and simulation. In this paper, we use MATLAB 2014a [5] software for create the total 9-Bus system Simulink model and total experiments has done.

2.4 Proposed Methodology

The proposed HIF detection method in this study aims to identify HIF by monitoring the phase current, using only the substation as an observable point. By the analysis of the phase current spectrograms and the state of the art. In the case of HIF detection, the signal processing technique is popular and this give most correct result. Here FFT has been used as signal processing tool.

3 FOURIER TRANSFORM

Frequency domain techniques can be used for obtaining the signals harmonic content. Since the FT can extract information about the magnitudes of the various signal frequencies and because it is widely used in the protection systems of Electric Power Systems (EPS), it is used in the methodology proposed by this work. For defining the Fourier transform of an integral function.

$$\hat{f}(\xi) = \int_{-\infty}^{\infty} f(x) e^{-2\pi i x \xi} dx, \quad \forall \xi \in \mathbb{R}. \quad (1)$$

The Fourier transform is denoted here by adding a circumflex to the symbol of the function. When the independent variable x represents time, the transform variable ξ represents the frequency.

Under suitable conditions f is determined by f via the inverse transform:

$$f(x) = \int_{-\infty}^{\infty} \hat{f}(\xi) e^{2\pi i x \xi} d\xi, \quad \forall x \in \mathbb{R}. \quad (2)$$

That is known as the Fourier inversion theorem [6].

In order to observe certain signal frequencies, the size, and consequently the number of samples in each window, can be changed, thus modifying the frequency resolution Δf of the signal with a sampling frequency f_s and N is number of samples.

$$\Delta f = \frac{f_s}{N} \quad (3)$$

Inter-harmonics are commonly found in HIF current waveforms, because they are associated with the random length variation of the electric arc during fault situations. In this condition, the larger the amplitude of the variation, the larger the number of inter-harmonic frequencies.

There are some processes of FT:

Continuous Fourier Transform (CFT), Discrete Fourier transforms (DFT), Discrete Time Fourier Transform (DTFT), Fast Fourier transforms (FFT), Short Time Fourier transforms (STFT).

4 DISCRETE FOURIER TRANSFORM

In mathematics, the discrete Fourier transform (DFT) converts a finite sequence of equally-spaced samples of a function into a same-length sequence of equally-spaced samples of the discrete-time Fourier transform (DTFT), which is a complex-valued function of frequency. The interval at which the DTFT is sampled is the reciprocal of the duration of the input sequence. An inverse DFT is a Fourier series, using the DTFT samples as coefficients of complex sinusoids at the corresponding DTFT frequencies.

The discrete Fourier transform transforms a sequence of N complex numbers

$$\{\mathbf{x}_n\} := x_0, x_1, \dots, x_{N-1} \quad (4)$$

into another sequence of complex numbers,

$$\{\mathbf{X}_k\} := X_0, X_1, \dots, X_{N-1},$$

Which is defined by

$$X_k = \sum_{n=0}^{N-1} x_n \cdot e^{-i \frac{2\pi}{N} kn} = \sum_{n=0}^{N-1} x_n \cdot \left[\cos\left(\frac{2\pi}{N} kn\right) - i \cdot \sin\left(\frac{2\pi}{N} kn\right) \right],$$

where the last expression follows from the first one by Euler's formula. The transform is sometimes denoted by the symbol F , as in

$F(x)$ or $X=F\{x\}$ or F_x . The discrete Fourier transform is an invertible. The inverse transform is given by:

$$x_n = \frac{1}{N} \sum_{k=0}^{N-1} X_k \cdot e^{i \frac{2\pi}{N} kn} \quad (5)$$

The DFT has seen wide usage across a large number of fields.

All applications of the DFT depend crucially on the availability of a fast algorithm to compute discrete Fourier transforms and their inverses, a fast Fourier transform (FFT).5 Equations

5 FAST FOURIER TRANSFORM

A fast Fourier transform (FFT) [7] is an algorithm that computes the discrete Fourier transform (DFT) of a sequence, or its inverse (IDFT). Fourier analysis converts a signal from its original domain (often time or space) to a representation in the frequency domain and vice versa. The DFT is obtained by decomposing a sequence of values into components of different frequencies. An FFT rapidly computes such transformations by factorizing the DFT matrix into a product of sparse (mostly zero) factors. As a result, it manages to reduce the complexity of computing the DFT from $O(N^2)$, which arises if one simply applies the definition of DFT, to $O(N \log N)$, where N is the data size and $N=2$ here. The difference in speed can be enormous, especially for long data sets where N may be in the thousands or millions. In the presence of round-off error, many FFT algorithms are much more accurate than evaluating the DFT definition directly or indirectly. Because $\lim_{N \rightarrow \infty} \frac{\log_2 N}{N} = 0$ it is a typical fast algorithm. Fast algorithms of this type of recursive halving are very typical in scientific computing. So, FFT is faster than DFT.

Applying DFT using a FFT algorithm reduces the time complexity required in practical applications. Thus, this work uses the FFT calculation in specific signal windows, making it possible to obtain values in the magnitude of all frequencies during the entire fault time. Therefore, the way the FFT is calculated for a discrete signal.

6 SOLUTION METHOD

Total work is done with the following stage by stage:

- First, IEEE 9-BUS standard system is created

with MATLAB Simulink model with standard value and run it in steady state performance using MATLAB 2014a software.

- Stage 2, In the system HIF is created at some location and done the simulation.
- Stage 3, after simulation we collected all date of faults.
- Stage 4, at last with creating the faults the FFT analysis is applied and all data are collected.

7 RESULT AND SOLUTION

Transmission line protection is an important issue in power system because 85-87% of power system faults are occurring in transmission line. This dissertation work gives technique to classify the different faults on transmission line for quick and reliable operation of protection schemes.

Transmission line faults are of mainly five types: L-G, L-L, L-L-G, L-L-L and L-L-L-G. But the effect of L-L-L and L-L-L-G faults is same. So, here we are considering only L-L-L fault. In all four different faults are classified after faulty condition is detected in the system. Order to detect the existence of HIFs, we propose to use FFT. The traditional approach uses FFT to detect HIF current of the event in a large size frame. By doing this, one could miss the existence of the HIF in the transient state where the duration of occurrence is very short.

All the fault cases are discussed in the results initially all the types of faults are made near bus 2 and bus 7. The cases of faults made at a distance of 25km are considered for the result analysis. Here, take the values and graphs of FFT for every type of HIF. By the result, It is observed that the how faults are detected very quickly with applying the FFT signal processing technique.

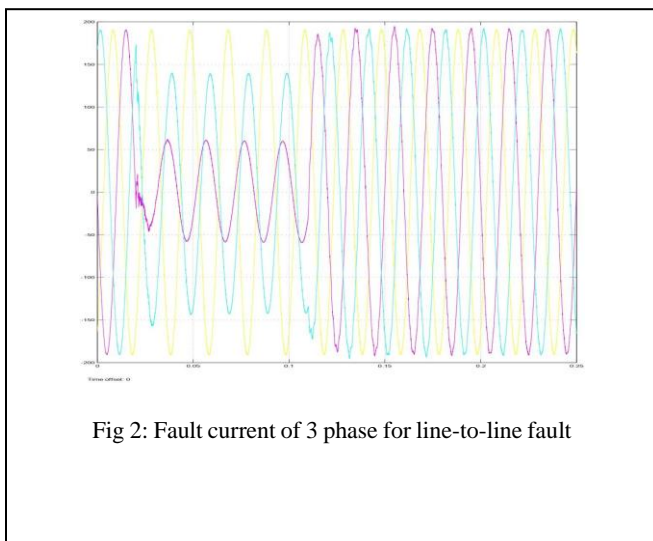

Fig 2: Fault current of 3 phase for line-to-line fault

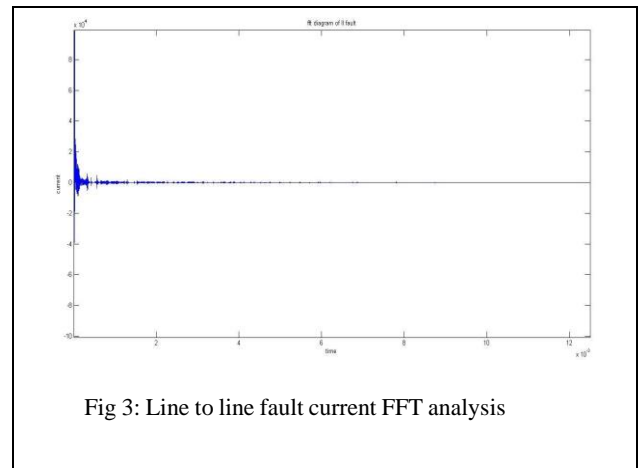

Fig 3: Line to line fault current FFT analysis

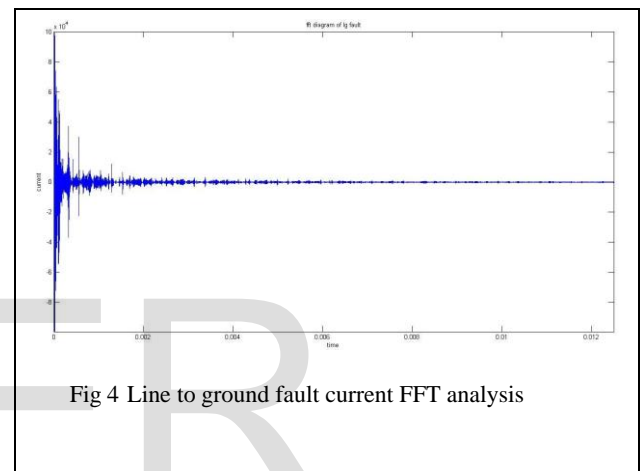

Fig 4 Line to ground fault current FFT analysis

It is observed that during the HIF, the value of current decrease from the nominal value, as shown in the diagram. When the Fault is removed, the system attends its normal value. Whereas the for the voltages, at the time of occurrence of the fault, there is large surges at that instant while the nature of the waveform is retained.

If a HIF detection method has only one sensor at the substation, it would be necessary to use the low-frequency content, which can be done either by harmonics or inter-harmonics. On the other hand, if the sensor is nearby the HIF location, it would be possible to use the current higher frequencies energy amplitude and variation for HIF detection.

In future, the protection system provided for the system should have fast response. According to this analysis, fast fault clearing and load shedding methodologies can be adopted for system stability and also be applied for finding fault location.

For future studies, the method can be applied in other test systems with topology variations like intelligence Artificial Neural Network (ANN).

4 CONCLUSION

The most relevant conclusions of the work reported in the [6] dissertation are highlighted below:

Comprehensive literature review revealed that the transient stability analysis for a grid connected photovoltaic system has been a challenging task for the power system engineers over the decade, specially the synchronization phenomena Simulation Modeling of 9 bus grid connected photovoltaic system with respect to a hardware setup is also of utmost importance as their behavioral studies can be conducted only with simulation for the sake of expense of real time monitoring.

A 3 input 9 bus grid connected SIMULINK model has been made with Photovoltaic system incorporated in it.

During the synchronization phenomena the utilization of phase lock loop has been a one of the latest implementation.

Various faults are created and the transient stability analyses are studied.

ACKNOWLEDGMENT

It is a pleasant task to express my gratitude to all those who have accompanied and helped me in my project work. First and foremost, I really take this opportunity to express my deep sense of gratitude to my guide, for her invaluable guidance, suggestions and encouragement throughout the project which helped me a lot to improve this project work. It has been very nice to be under his guidance. His appreciation during the good times has been boosting my morals. I have been extremely lucky to have him as my guide. My heart-felt thanks to all my family members for their moral support and encouragement, without which, the work would not have been possible. Last but not least, I extend my thanks and appreciation to my friends, colleagues, batch-mates and everyone who have helped me directly or indirectly to get this work done..

REFERENCES

- [1] "Calculation of AC Short circuit current at MMC-HVDC Converter Station" Xinjia Song, Qianhong Shi, Yipin Gong, Luhua Xing, Zhijun Wang, Lei Ding, 6th Asia Conference on Power and Electrical Engineering (ACPEE), 2021.
- [2] "Electrodynamics basics and duality principle" A. M. Ioanitiky 2013 IX International Conference on Antenna Theory and Techniques.
- [3] "Research on Short Circuit Test of 500 kV Hybrid HVDC circuit breaker".Zhao Shu-Zhen; Zhang Jin-Xiang; Li Zhen-Dong; Yu Wen-Bo; Wang Yu-Qiang; Niu Xue-Fei; Kan Shi-Yang 2017 International Conference on Smart Grid and Electrical Automation (ICSGEA).
- [4] "Fast fourier transform in the spiral honeycomb image algebra".P. Sheridan;D.M. Alexander;K.S. Nunn-Clark.Third International Conference on Information Technology and Applications (ICITA'05). Vol - 1, 2005.
- [5] "MATLAB Programming Environment Based on Web".Liu Yu, 2018 IEEE 4th Information Technology and Mechatronics Engineering Conference (ITOEC).

[6] "An efficient Fourier method for 3-D radon inversion in exact cone-beam CT reconstruction".S. Schaller;T. Flohr;P. Steffen, IEEE Transactions on Medical Imaging Year: 1998 Volume: 17, Issue: 2.

[7] "DIFFT: A Fast and Accurate Algorithm for Fourier Transform Integrals of Discontinuous Functions" Yanhui Liu;Zaiping Nie;Qing Huo Liu, IEEE Microwave and Wireless Components Letters Year: 2008, Volume: 18, Issue: 11.